



DIGITAL MICROWAVE OVEN



- 10** Power Level Settings
- 9** Auto-cook Menu With Preset Settings
- 7** Express Cooking
- LED** Panel Display

20 **LITERS**
CAPACITY

- Weight & Time Defrost
- Kitchen Timer
- Door Release Button
- 700W Power

FOR HOUSEHOLD USE ONLY

imartec® Corporation

MO-J20DB

SPECIFICATION

Model no.	:	MO-J20DB
Voltage	:	230V a.c. 60Hz
Input Power	:	1100W
Rated Microwave Power Output	:	700W
Microwave Frequency	:	2450MHz
Box Dimension	:	470mm(W)*355mm(D)*267mm(H)
Unit Dimension	:	445mm(W)*325.5mm(D)*242mm(H)
Oven Cavity Dimension	:	297mm(W)*296mm(D)*208mm(H)
Gross Weight	:	10.67KG
Unit Weight	:	9.90KG
Oven Capacity	:	20liters

IMPORTANT SAFEGUARDS

The following basic precautions should always be followed when using electrical appliance:

1. Read all instructions before using.
2. Make sure the voltage in your convenience outlet corresponds to the one shown on the rating label of the appliance.
3. Do not use any appliance with a damaged cord or plug. If the cord is damaged it should be replaced with the same type and size or bring the unit to the nearest authorized service center.
4. Use the oven only for its intended use or as described in this manual. Do not use corrosive chemicals. This oven is not designed for industrial and laboratory use.
5. Do not operate the oven if empty.
6. To reduce the risk of fire in the oven cavity:
 - a. Do not overcook the food.
 - b. When heating food in plastic or paper containers, check the oven frequently for possible ignition.
 - c. Remove wire twist-ties from paper or plastic bags before placing bags in the oven.
 - d. Do not use the cavity for storage purposes. Do not leave paper products, cooking utensils or food in the cavity when not in use.
 - e. Do not heat oil or fat for deep drying as the temperature of oil cannot be controlled.
 - f. After use wipe the waveguide cover with a damp cloth, followed by dry cloth to remove any food splashes and grease. Built-up grease may overheat and begin to cause smoke or catch fire.
 - g. If materials inside the oven should smoke or ignite, keep oven door closed, turn oven off and disconnect from the convenience outlet.
 - h. Close supervision is necessary when using disposable containers made from plastic, paper or other combustible material.
7. To reduce the risk of explosion and sudden boiling:
 - a. Do not place sealed containers in the oven. Baby bottles fitted with a screw cap or teat are considered to be sealed containers.
 - b. When boiling liquid in the oven, use the wide-mouthed container and stand about 20 seconds at the end of cooking to avoid delayed eruptive boiling of liquids. Handle the container with care.
 - c. Potatoes, sausage and chestnut should be peeled or pierced before cooking. Eggs in their shell, whole hard-boiled eggs should not be heated in microwave ovens since they may explode, even after microwave heating has ended.

- d. The cooked liquid should not be removed out immediately. Several moments should be waited before removing in order to avoid possible hazards caused by delayed eruptive boiling of liquids.
 - e. The contents of feeding bottles and baby food jars are to be stirred or shaken and the temperature is to be checked before consumption, in order to avoid burns.
8. Never operate the oven further if the door or door seals are damaged or the oven is malfunctioned or supply cord is damaged. Return the appliance to the nearest authorized service center for repair and maintenance. Never try to adjust or repair the oven yourself.
9. After cooking, the container is very hot, use gloves to take out the food and avoid steam burns by directing steam away from the face and hands.
10. Slowly lift the furthest edge of dishes cover and microwave plastic wrap and carefully open popcorn and oven cooking bags away from the face.
11. To prevent the turntable from breaking:
 - a. Allow the turntable cool before cleaning.
 - b. Do not place hot foods or utensils on the cold turntable.
 - c. Do not place frozen foods or utensils on the hot turntable.
12. Make sure the utensils do not touch the interior walls during cooking.
13. Cookware/containers should be checked to ensure that they are suitable for microwave use.
14. Metallic containers for food and beverages are not allowed during microwave cooking.
15. Only use utensils that are suitable for use in microwave ovens.
16. Failure to maintain the oven in a clean condition could lead to deterioration of the surface that could adversely affect the life of the appliance and possibly result in a hazardous situation.
17. Do not operate the oven without any liquid or food inside the oven. This could damage the oven.
18. The microwave oven is intended for heating food and beverages. Drying of food or clothing and heating of warming pads, slippers, sponges, damp cloth and similar may lead to risk of injury, ignition or fire.
19. Extra caution must be exercised when removing the container from the appliance. Turntable should not be displaced in the appliance when removing the container.
20. If smoke is observed, switch off or unplug the appliance and keep the door closed in order to stifle any flames.
21. Children should be supervised to ensure that they do not play with the appliance.
22. This appliance is not intended for use by persons (including children) with reduced physical, sensory or mental capabilities, or lack of experience and knowledge, unless they have been given supervision or instruction concerning use of the appliances by a person responsible for their safety.
23. Any accessories not recommended by the manufacturer may **CAUSE** injuries to persons.
24. Do not use outdoors.
25. The appliance is only intended to be used as freestanding. Do not use other that its intended use.
- 26. For household use only; not intended for any business purposes**
27. Save these instructions.

OPERATION THEORY OF MICROWAVE OVEN

1. Microwave is a kind of high frequency electromagnetic wave, which is commonly distributed in the nature. But the existing form of microwave is dispersed so that it cannot be collected together for heating purpose. The key component of magnetron of microwave oven will transform the energy of electricity to microwave and huge energy of microwave field is established under the closed cavity. So, the molecule of food is caused to vibrate at very high speed and the friction heat produced will cook the food in a fast way.
2. There are 3 properties of microwave, that is
 - a. Absorbability: the microwave can cause the excess vibration of molecule of various foods so as to obtain the heating purpose. But the infiltration ability is largely depending on the size, thickness and properties of the food.
 - b. Penetrability: microwave can penetrate through ceramics, glass, temperature-resistant plastics. It is required to use the containers whose material have good microwave penetrability to achieve best heating result. Please see the below cookware guide.
 - c. Reflectivity: microwave would be reflected by the metal wall of interior cavity so as to establish an even magnetic field, thus can prevent the overheating of partial area.

INSTALLATION

1. Remove all packaging materials.
2. **WARNING:** Check for any damages, such as misaligned or bent door, damaged door seals and sealing surface, broken or loose door hinges and latches. If there is any damage do not use the oven.
3. The oven should be placed on a stable surface to hold its weight.
4. Do not place near gas stove, electric burner or a heated oven.
5. The minimum installation height is 85 cm.
6. The oven must have sufficient airflow; allow 30cm of space above the oven, 20cm at the back and 20cm on both sides. Do not cover or block air vent or any openings of the oven. Do not remove the stand.
7. Do not use the oven without the turntable, roller ring and shaft in their proper positions.
8. The socket should be accessible so that it can be easily unplugged in case of emergency.
9. Do not use the oven outdoors.
10. Make sure that the power supply cord is undamaged and does not run under the oven or over any hot or sharp surface.

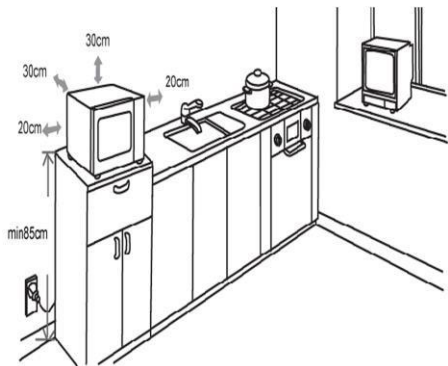

RADIO INTERFERENCE

1. Operation of microwave oven can cause interference to radio, TV or similar appliance.
2. When there is interference, it may be eliminated by:
 - a. Cleaning the door and sealing surface of the oven.
 - b. Plug the oven into a different out so that the oven and receiver are on different branch circuit.

PRECAUTIONS TO AVOID POSSIBLE EXPOSURE TO EXCESSIVE MICROWAVE ENERGY

1. Do not place any object between the door safety lock system or allow small solid particles or cleaner residue to accumulate on sealing surfaces.
2. Do not operate the oven if it is damaged. It is important that the oven is properly closed and there are no damages like:
 - a. Bent doors.
 - b. Broken or loosened hinges and latches.
 - c. Leaks on door seals and sealing surfaces.
3. The oven should not be adjusted or repaired by anyone aside from an authorized Imarflex service technician.
4. Do not tamper the safety interlocks.

IF THE MICROWAVE FAILS TO OPERATE

1. Check to ensure that the oven is plugged in securely. If not, unplug the unit, wait for 10 seconds and plug it again.
2. Check for a blown circuit fuse or a tripped main circuit breaker. If there's no problem with the supply of electricity, test the outlet with another appliance.
3. Check to ensure that the control panel is programmed correctly.
4. Check to ensure that the door is properly closed

FOR INITIAL USE

As there is manufacturing residue or oil remained on the oven cavity or heat element, it would smell the odor or a slight smoke. It is normal case and would not occur after several use. Keep the door or window open to ensure good ventilation.

MICROWAVE COOKING TIPS

1. Arranging food
 - Place thicker areas toward outside of dish and the thinner meat in the center and spread them evenly. Do not overlap if possible.
2. Cooking time
 - Start cooking with the shorter period of time and extend it according to the actual need. Overcooking may result in smoking and burning.
3. Cover foods before cooking refers to the recipe
 - Use paper towels, microwave plastic wrap or a cover-to-cover food to prevent spattering and help foods to cook evenly.
5. Stir foods
 - From outside to center of dish once or twice during cooking, if possible.
6. Turn foods
 - Foods such as chicken, hamburgers or steaks should be turned over once during cooking.
7. Rearrange foods
 - Please change the positions of food in half way during cooking such as: from top to bottom and from the center of the dish to the outside.
8. Allow standing time
 - After cooking ensure adequate standing time. Remove food from oven and stir if possible. Cover for standing time which allows the food to finish cooking without overcooking.

9. Check for doneness

- Observe the food color and hardness to determine whether the food is cooked. Doneness signs include:
 - Steams throughout food, not just at edge part.
 - Joints of Poultry move easily.
 - Pork and poultry show no evidence of blood.
 - Fish is opaque and flakes easily with a fork.

10. Condensation

- It is a normal case of microwave cooking. The humidity and moisture of food will influence the amount of moisture in the oven. Generally, covered foods will not cause as much condensation as uncovered foods. Ensure that the ventilation openings are not blocked.

11. Microwave safe plastic wrap

- For cooking food with high fat content, do not bring the wrap in contact with the food as it may melt.

12. Microwave safe plastic cookware

- Some microwave safe plastic cookware is not suitable for cooking foods with high fat and sugar content.

COOKWARE GUIDE

1. Ideal material should be transparent to microwave. Use clear or plain white cookware. It allows energy to pass through the container and heat food.
2. Do not use reflective materials such as stainless steel, aluminum foil, etc.
3. Do not use recycled paper products as they may contain small metals that can cause sparks or fire.
4. Use round containers rather than oblong and square containers because food in corners tend to be overcooked.
5. Use the data below as reference.

Utensils	Remarks
Browning Dish	Follow manufacturer's instructions. The bottom of browning dish must be at least 3/16 inch (5mm) above the turntable. Incorrect usage may cause the turntable to break.
Dinnerware	Microwave-safe only. Follow manufacturer's instructions. Do not use cracked or chipped dishes.
Glass jars	Always remove lid. Use only to heat food until just warm. Most glass jars are not heat resistant and may break.
Glassware	Heat-resistant oven glassware only. Make sure there is no metallic trim. Do not use cracked or chipped dishes.
Oven cooking bags	Follow manufacturer's instructions. Do not close with metal tie. Make slits to allow steam to escape.
Paper plates and cups	Use for short-term cooking/warming only. Do not leave oven unattended while cooking.
Paper towels	Use to cover food for reheating and absorbing fat. Use with supervision for a short-term cooking only.

Parchment Paper	Use as a cover to prevent splattering or a wrap for steaming.
Plastic	Microwave-safe only. Follow the manufacturer's instructions. Should be labeled "Microwave Safe". Some plastic containers soften, as the food inside gets hot. "Boiling bags" and tightly closed plastic bags should be slit, pierced or vented as directed by package.
Plastic wrap	Microwave-safe only. Use to cover food during cooking to retain moisture. Do not allow plastic wrap to touch food
Thermometers	Microwave-safe only (meat and candy thermometers).
Wax paper	Use as a cover to prevent splattering and retain moisture.

Materials to be avoided in microwave oven

Utensils	Remarks
Aluminum tray	May cause arcing. Transfer food into microwave-safe dish.
Food carton with metal handle	May cause arcing. Transfer food into microwave-safe dish.
Metal or metal-Trimmed utensils	Metal shields the food from microwave energy. Metal trim may cause arcing.
Metal twist ties	May cause arcing and could cause a fire in the oven.
Paper bags	Plastic foam may melt or contaminate the liquid inside when exposed to high temperature.
Plastic foam	Wood will dry out when used in the microwave oven and may split or crack.
Wood	Use to cover food for reheating and absorbing fat. Use with supervision for a short-term cooking only.

DESCRIPTION OF PARTS



Turntable Installation



- a. Never place the glass tray upside down.
- b. Both glass tray and turntable ring assembly must always be used during cooking.
- c. All food and containers of food are always placed on the glass tray for cooking.
- d. If glass tray or turntable ring assembly cracks or breaks, contact your nearest authorized service center.

OPERATING INSTRUCTION

1. Power Level

Level	10	9	8	7	6	5	4	3	2	1
Power	100%	90%	80%	70%	60%	50%	40%	30%	20%	10%
Display	100P	90P	80P	70P	60P	50P	40P	30P	20P	10P

2. Clock Setting

The clock function and "0" button are combined in one button. The clock is 24-hour system. The operation of the clock function is as follows:

In standby mode, press and hold down the "0/Clock" button for more than 3 seconds to enter the clock setting interface, press the 0 ~ 9 number buttons to input the clock time directly.

After pressing 4 number buttons consecutively, confirm the set time directly and exit the clock setting mode at the same time.

If you do not press 4 times, you need to press the "START/+30s" button to confirm the set time and exit the clock setting mode at the same time.

3. Kitchen Timer

- Press "**TIMER**", 0:00 will appear on the display, the hour figure flash.
- Press the number keys and enter the desired timer (the maximum time is 99 minutes and 99 seconds).
- Press "**START/+30SEC.**" to confirm setting.
- When the time is up, 5 beeps will be heard.

Note:

- The Kitchen Timer is different from a 12-hour system, Kitchen Timer is a timer.
- While using the Kitchen Timer, other functions cannot be used. Press "**STOP/Cancel**" twice to cancel the Kitchen Timer function.

4. Microwave Cooking

- Press "**POWER**" once, LED will display "100P". The default power is 100% power. Press again the POWER button to adjust to desired Power Level.
- Press number keys to input the cooking time; the maximum cooking time is 99 minutes and 99 seconds.
- Press "**START/+30SEC.**" to start cooking.

Example: To cook the food with 50% microwave power for 15 minutes.

- Press "**POWER**" 6 times to select 50% microwave power. 50P will appear on the LED.
- Press "1", "5", "0", and "0".

3. Press "**START/+30SEC.**" to start cooking.

Note:

1. In the process of setting, if the "**STOP/CANCEL**" button is pressed or if there is no operation within 1 minute, the oven will go back to the former setting automatically.

5. Express Cooking

- a. In waiting state, instant cooking at 100% power level can be started by selecting a cooking time from 1 to 6 minutes by pressing number pads 1 to 6. Press "**START/+30SEC.**" to increase the cooking time; the maximum cooking time is 99 minutes and 99 seconds.
- b. In waiting state, instant cooking at 100% power level with 30 seconds' cooking time can be started by pressing "**START/+30SEC**". Each press on the same button will increase cooking time by 30 seconds. The maximum cooking time is 99 minutes and 99 seconds.

Note:

1. During microwave cooking and time defrost, time can be added by pressing "**START/30SEC.**" button.

6. Weight Defrost Function

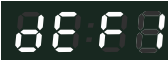
- a. Press "**DEFROST**", LED will display "dEF1". 
- b. Press numerical buttons to input the weight, it should only be from 100 to 1500 grams.
- c. Press "**START/+30SEC.**" to start defrosting.

Note:

1. Each grams selected correspond with default defrosting time.

7. Time Defrost Function

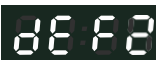
- a. Press "**DEFROST**" twice, LED will display "dEF2". 
- b. Press numerical buttons to input defrosting time. The time range is 00:01~99:99.
- c. Press "**START/+30SEC.**" to start defrosting.

8. POTATO

- a. Press "**POTATO**" repeatedly until the number of grams you wish appears in the display.
- b. Press "**START/+30 SEC.**" to cook.
- c. When cooking time is finish, beep sound five times and then turns back to waiting state.

Guide

Press once, approximate 250 gram with 7 minutes.
Press twice, approximate 500 grams with 10 minutes.
Press thrice, approximate 750 grams with 14 minutes.

9. PASTA

- a. Press "**PASTA**" repeatedly until the number you wish appears in the display, "50", "100", "150" g will display in order. For example, press "**PASTA**" once, "100" will appear on the display. Each gram corresponds with a default cooking time.
- b. Press "**START/+30 SEC.**" to cook. When cooking time is finish, beep sound five times and then turns back to waiting state.

10. PIZZA

- a. Press "**PIZZA**" repeatedly until the number you wish appears in the display, "200", "400" g will display in order. For example, press "**PIZZA**" once, "200" will appear on the display. Each gram corresponds with a default cooking time
- b. Press "**START/+30 SEC.**" to cook. When cooking time is finish, beep sound five times and then turns back to waiting state.

11. POPCORN

- a. Press "**POPCORN**" once, "100" will appear in the display. Number shown correspond with the grams.
- b. Press "**START/+30 SEC.**" to cook, beep will sound five times and then turn back to waiting state.

Guide

1. It is suggested that you fold down a triangle on each corner of the bag before cooking. Refer to the picture at right.



2. If/When the popcorn bag expands and no longer rotates properly, please press **STOP/CANCEL** button once and open the oven door and adjust the bag position to ensure even cooking.

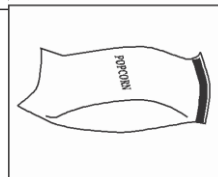

12. FROZEN VEGETABLE

- a. Press "**FROZEN VEGETABLE**" repeatedly until the number you wish appears in the display, "200", "400", "600" g will display in order. For example, press "**FROZEN VEGETABLE**" once, "200" will appear on the display. Each gram corresponds with a default cooking time.
- b. Press "**START/+30 SEC.**" to cook. When cooking time is finish, beep sound five times and then turns back to waiting state.

13. BEVERAGE

- a. Press "**BEVERAGE**" repeatedly until the number you wish appears in the display,

"1", "2", "3" cup will display in order. One cup is about 120ml. For example, press "**BEVERAGE**" once, "1" will appear on the display. Each number corresponds with a default cooking time.

- b. Press "**START/+30 SEC.**" to cook. When cooking time is finish, beep sound five times and then turn back to waiting state.

14. MEAT

- a. Press "**MEAT**" repeatedly until the number you wish appears in the display, "200", "400", "600" g will display in order. For example, press "**MEAT**" once, "200" will appear on the display. Each setting corresponds with a default cooking time.
- b. Press "**START/+30 SEC.**" to cook. When cooking time is finish, beep sound five times and then turn back to waiting state.

15. FISH

- a. Press "**FISH**" repeatedly until the number you wish appears in the display, "200", "400", "600" g will display in order. For example, press "**FISH**" once, "200" will appear on the display. Each setting corresponds with a default cooking time.
- b. Press "**START/+30 SEC.**" to cook. When cooking time is finish, beep sound five times and then turn back to waiting state.

16. REHEAT

- a. Press "**REHEAT**" repeatedly until the number you wish appears in the display, "200", "400", "600", "800", "1000" g will display in order. For example, press "**REHEAT**" once, "200" will appear on the display. Each gram corresponds with a default cooking time.
- b. Press "**START/+30 SEC.**" to cook. When cooking time is finish, beep sound five times and then turn back to waiting state.

17. LOCK FUNCTION FOR CHILDREN

- a. In waiting state, press "**STOP/CANCEL**" for 3 seconds, there will be a long "beep" denoting that the microwave is in child-lock state; meanwhile, LED will display a key icon.
- b. In locked state, press "**STOP/CANCEL**" for 3 seconds, there will be a long "beep" denoting that the microwave is unlocked.

18. COOKING END SIGNAL

- a. When the cooking is over, a beep sound will be heard to alert user that cooking is finished.

19. EXPRESS COOKING

- a. In stand-by mode, press the numbers from 1 to 6 to start cooking.

Number	Time
Start	30 seconds
1	1 minute
2	2 minutes
3	3 minutes
4	4 minutes
5	5 minutes
6	6 minutes

CLEANING AND MAINTENANCE

The oven should be cleaned regularly:

1. Unplug the oven from the convenience outlet before cleaning.
2. Do not allow food splatters or spilled liquids adhere to oven walls. Baking soda may be used if the oven gets very dirty. Avoid using spray and other harsh cleaners as this may stain, streak, or dull the door surface.
3. Use damp cloth in cleaning the glass window and the surface of the oven.
4. Do not allow water to seep into the ventilation openings to avoid damages on the operating parts.
5. If the steam accumulates inside or around the oven door, dry it using soft cloth. This may occur when the oven is operated under high humid conditions, but this is normal.
6. If the glass turntable becomes dirty, remove it and wash it with soap and water.
7. The roller rest and oven floor should be cleaned regularly to avoid excessive noise. Simply wipe the bottom part of the oven with mild detergent. The roller ring can be washed with soap and water. If the roller rest is removed from the oven, be sure to return it properly.
8. Never use hard detergent, gasoline, abrasive powder or metal brush to clean any part of the appliance.
 - a. Exterior:
 - Wipe with damp cloth. Do not use abrasive materials to avoid scratches.
 - b. Door:
 - Wipe both sides of the door and the door seals frequently with a damp cloth to remove any spills or spatters.
 - c. Control Panel:
 - Care should be taken in cleaning the control panel. Wipe the panel with a damp cloth slightly. Do not scrub or use any sort of chemical cleaners.
 - d. Interior:
 - To clean the interior surfaces and wave guide, wipe with damp cloth to remove any food splashed.
 - Build up splashes may cause overheat and begin to smoke or catch fire, make sure to remove by wiping it with damp cloth.

- Do not remove the waveguide cover.
- Do not use a commercial oven cleaner, abrasive or harsh cleaners and scouring pads on any part of your microwave oven.
- Never spray oven cleaners directly onto any part of your oven.

TIPS: When the microwave oven has been used for a long time, there may be some strange odors in the oven, follow these steps to get rid of them:

- a. Place several lemon slices in a cup, then heat with high power for 2-3 min.
- b. Place a cup of red tea in the oven, and then heat with high power.
- c. Put some orange peel into oven, and then heat them with high power for 1 minute.
- e. Turntable/ Rotating ring/Rotating shaft:
 - Wash with mild soapy water and dry thoroughly.